

Model : LCF-800

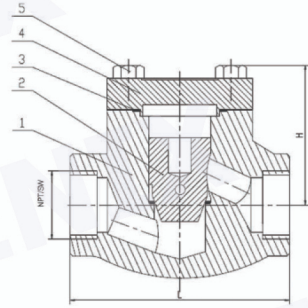

Materials

NO.	Partname	Material
1	Body	ASTM A105 / F22
2	Disc	A182 F6a + STL
3	Gasket	304 + graphite
4	Bonnet	ASTM A105 / F22
5	Bolt	ASTM A193 B7

Specification standards

- Basic design : API 602
- Basic design : API 598
- Screw end dimension : ANSI B1.20.1
- Socket welding dimension : ASME B16.11

Test Requirements Class 800P

Working Pressure : 800PSI (55 bar)
 Shell test Pressure : 1200PSI (82 bar)
 Applicable temperature : <425° C

Test Requirements Class 1500P

Working Pressure : 1500PSI (103 bar)
 Shell test Pressure : 2200PSI (155 bar)
 Applicable temperature : <425° C

Features

- Bolted bonnet
- Pressure Rating class : 800P, Trim 8
- Pressure Rating class : 1500P, Trim 5

Application

- For general and industrial services
- Applicable medium : water, stem, oil and gas

Dimension

mm

Size		1/2	3/4	1	1 1/4	1 1/2	2
Class800P	L	79	92	111	120	152	172
	H	62	63	78	82	102	120
Class1500P	L	111	111	120	152	172	221
	H	98	98	104	120	140	158