

## GATE VALVE

*Forged steel (Class 800)*

**Model : GT-800**



### Standards

Threaded ends:  
ASME B1.20.1  
Socket welding ends : ASME B16.111  
Inspection and test : API598

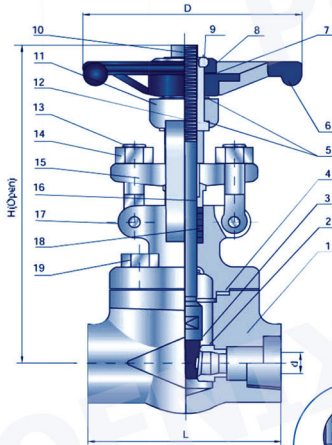

### Materials

NO.	Partname	Material
1	Body	ASTM A105N
2	Seat ring	A276 410/Stelite overly
3	Wedge	ASTM A276 420
4	Gasket	304SS Spiral wound Wound W/Graphite
5	Washer	ASTM A276 420
6	Handwheel	Malleable iron
7	Nameplate	Aluminium
8	H.W.Lock Nut	ASTM A108 1020
9	Bolt	ASTM A
10	Stem	ASTM A182 F6a
11	Bonnet	ASTM A105N
12	Stem nut	Aluminum Bronze
13	Eyebolt	ASTM A276 410
14	Eyebolt nut	ASTM A194 Gr.2H
15	Gland Flange	ASTM A105N
16	Gland	ASTM A276 410
17	Eyebolt Pin	ASTM A276 410
18	Packing	Graphite
19	Bolt	ASTM A193 Gr.B7

### Dimension

Size	DIM (MM)				Wt (Kg)		
	CONV.	d	L	H	BB	WB	
1/2		9.5	79	158	100	2.0	1.7
3/4		12.7	92	169	100	2.3	2.0
1		17.5	111	197	125	4.3	3.8
1 1/4		23.8	120	236	160	5.9	5.1
1 1/2		28.6	120	246	160	6.9	6.1
2		36.5	140	283	180	11.1	10.2