

# PHOENIX

## PH SERIES QUARTER TURN ELECTRIC ACTUATOR



## “PHOENIX” PH Series Quarter Turn Electric Actuator

‘PH’ series electric actuators are designed & engineered for robust, reliable and for high performance duty onto quarter turn valves. The unique reliable motor module, adjustable cam plate limit switch, self locking mechanism, precision gearing system and ball bearings, the auto declutching mechanism, light force load on the hand-wheel, the adaptor drive bushing and bottom ISO 5211 mounting dimension, are added advantages against others in the field of valve automation. CE approved. FM & UL pending.

### 1. ENCLOSURE

Standard enclosure to water jet proof & water tight proof IP 67, NEMA 4 & 6.

### 2. MOTOR

Squirrel cage motor is of encapsulated type, on high stall torque and low inherent force for seating & unseating of valves. All motors are integrated with build-in thermal protection.

### 3. TERMINAL CONNECTION & WIRING

Terminal connections are of “WAGO” push on type, making wiring connection very easy & without fuss. Electrical wiring circuit is standardized for single & three phase voltage. Addition termination is available on request.

### 4. INTERNAL COMPONENTS ARRANGEMENT

Internal mechanical and electrical components are designed in modular mounting arrangement, and can be easily removed for maintenance purposes. Addition optional accessories are also possible.

### 5. LIMIT SWITCHES

A pair of limit switches are activated by means of simple, reliable & adjustable cam plates, mounted directly onto, and driven by center column. The unique cam plate design does not allow over travel of limit switches.

### 6. TORQUE SWITCHES

Electric actuators on 100 Nm and above, are installed with torque switches for over-load protection.

### 7. HEATER

For prevention of condensation due to weather & temperature changes, and also keeps internal components clean & dry, a 20 watt space heater is provided inside all the electric actuators.

### 8. SELF LOCKING MECHANISM

Because of the worm gear design system, all the electric actuators are self locking.

### 9. HANDWHEEL

Correct size of hand-wheel on the electric actuator ensure adequate strength for safe and efficient emergency operation.

### 10. MANUAL OVER-RIDE

Engage by pulling the lever & turning the handwheel. Lever is auto declutch when power supply is switched on, and hand-wheel does not turn as extra safety feature.

### 11. VISUAL POSITION INDICATOR

The visual position indicator is directly mounted onto the center drive column to provide the visual position of the valve.

### 12. END STOPPERS

1 each for open & close position (adjustable), are for over travel protection.

### 13. POTENTIOMETER - optional

Is available on request, is to provide & transmit remote indication of valve position.

### 14. MOUNTING & ADAPTATION

Bottom flange mounting dimension conform to ISO 5211. A adaptor drive bushing is provided for every electric actuator, is removable and for machining to suite valve stem size.



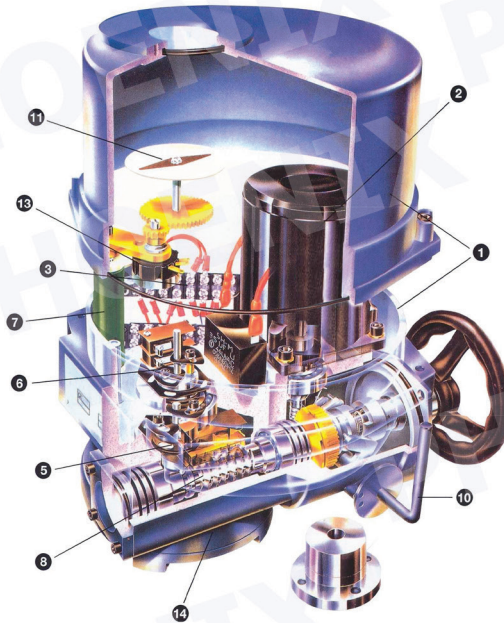

## Application

For quarter turn valves automation used in heating & ventilation, air-conditioning, water treatment works, power generation, petrochemical plants, oil storage facilities, chemical plants, effluent treatment works, pulp & paper mills and shipbuilding industry.

## • Performance

Type	Max Output Torque Kg-m	Operating Time 60/50 Hz. 90 Deg.	Max Stem Dia. mm	Motor 30 Min. Class F W	Rated Current (mA)				Number of Handle Turn	Weight (Kgs)
					1 Phase		3 Phase			
					110V	220V	380V	440V		
PH3*	3	14/17	14	10	650	300	N/A	N/A	8.5	6
PH4*	4	14/17	14	10	650	300	N/A	N/A	8.5	6
PH6*	6	14/17	22	15	1250	400	N/A	N/A	8.5	9
PH9*	9	14/17	22	25	1500	550	190	400	8.5	10
PH15	15	17/20	22	40	2000	900	280	400	10	12
PH19	19	17/20	22	40	2000	900	280	420	10	13
PH28	28	22/26	32	40	2000	900	280	450	12.75	17
PH38	38	22/26	32	60	2700	1250	400	450	12.75	18
PH50	50	22/26	32	90	3300	1600	600	450	12.75	19
PH60	60	24/29	42	120	5000	2400	800	500	14.5	22
PH80	80	24/29	42	180	5800	2800	1200	850	14.5	23
PH100	100	24/29	42	200	8000	3000	1300	900	14.5	25
PH150	150	75/90	50	180	5800	2800	1200	850	45	33
PH200	200	75/90	50	200	8000	3000	1300	900	45	35
PH250	250	75/90	50	200	8000	3000	1300	900	45	35

\* Without torque switches

## • Dimensions

Type	PH150	PH200	PH250
Flange	F16	F16	F16
ISO5211	F14	F14	F14
C	160	160	160
A	M20	M20	M20
B	30	30	30
D (Max)	50	50	50
E	95	95	95
F	60	60	60
G	4	4	4
H	241	241	241
I	191	191	191
J	264	264	264
L	210	210	210
O	350	350	350
T	132	132	132
X	357	357	357
Y	323	323	323
Z	505	505	505

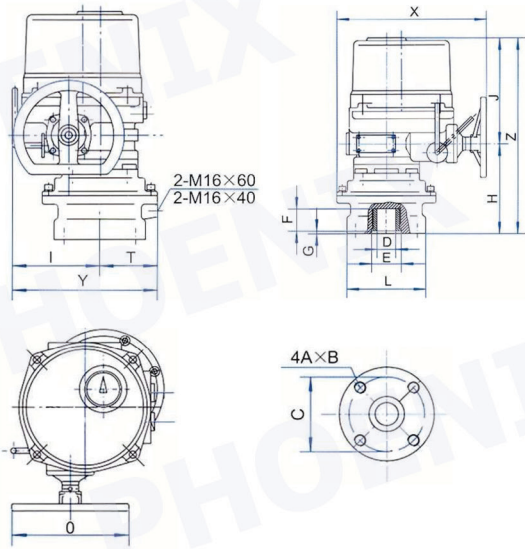

## Standard Specification

Housing & Cover	Aluminium, Anodized
Enclosure	Watertight IP67, Nema4 and 6
Ambient Temp	-30°C to + 70°C
Power Supply (60Hz/50Hz)	110/220VAC, 1 Phase 380/440VAC, 3 Phase
Control Power	110/220VAC, 1 Phase, 60/50Hz
Torque Switches	2 x SPDT for QT15 and above
Limit Switches	2 x SPDT 15A
Stall Protection	Built-in Thermal Protection
Travel Angle	90° ± 5°
Indicator	Continuous Position Indicator
Manual Override	HAND/AUTO Declutching Mechanism
Self Locking	Provide by means of Worm Gearing
End Stopper	External Adjustable Screws
Space Heater	20W for Anti-Condensation
Conduit Entries	Two G3/4"
Lubrication	MoS2 Lithium Base Grease
Materials	Steel, Aluminium Alloy, Al Bronze
External Coating	Dry Powder, Epoxy-Polyester Munsell No. FJ-002

## Optional Items

ALS	Additional 2 x SPDT Auxiliary Limit Switches
EXT	Travel Angle 120°, 135°, 180°, 270°
LCB	Local Control Box (1) Local/Remote Selector Switch (2) Open/Stop/Close Selector Switch
POT	Potentiometer 1k Ohm
CPT	Current Position Transmitter Output; 4-20mA DC
PCM	Proportional Control Module Input signal: 4-20mA, 1-5V DC Output Signal: 4-20mA DC
EXP	Explosion & Water Proof Enclosure Exd II BT4 IP67



## PH03,PH04,PH06,PH09,PH15,PH19,PH28,PH38,PH50,PH60,PH80,PH100

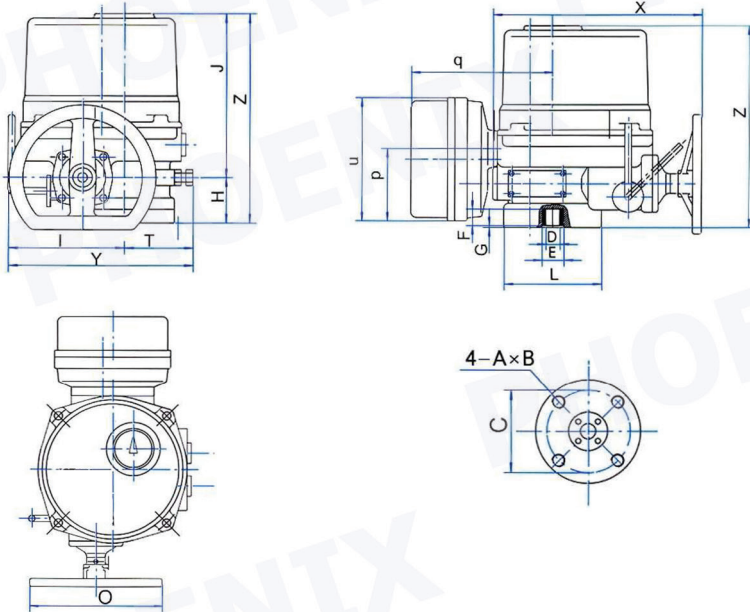

### • Dimensions

Type	PH3	PH4	PH6	PH9	PH15	PH19	PH28	PH38	PH50	PH60	PH80	PH100
Flange ISO5211	F05	F05	F05	F07	F07 F10	F07 F10						
C	50	50	50	70	70 102	70 102						
A	M6	M6	M8	M8	M8 M10	M8 M10						
B	12	12	12	12	15 15	15 15	18	18	18	18 20	18 20	18 20
D (Max)	14	14	14	22	22	22	32	32	32	42	42	42
E	40	40	55	55	57	57	75	75	75	85	85	85
F	25	25	35	35	35	35	42	42	42	50	50	50
G	5	5	5	5	5	5	1.2	1.2	1.2	1	1	1
H	60	60	60	60	64	64	70	70	70	78	78	78
I	133	133	133	133	154	154	174	174	174	191	191	191
J	196	196	196	196	199	199	228	228	228	264	264	264
L	102	102	102	102	125	125	145	145	145	175	175	175
O	200	200	200	200	250	250	350	350	350	350	350	350
T	75	75	75	75	85	85	100	100	100	115	115	115
X	241	241	241	241	272	272	290	290	290	331	331	331
Y	208	208	208	208	239	239	274	274	274	306	306	306
Z	256	256	256	256	263	263	298	298	298	342	342	342
P	72	72	72	72	72	72	72	72	72	72	72	72
q	166	166	166	166	187	187	192	192	192	209	209	209
U	170	170	170	170	170	170	170	170	170	170	170	170